

FEIDER



AIRLESS PAINT SPRAYER

AIRWIN1000W

INSTRUCTION MANUAL

CAUTION Read the instructions before using the machine

CONTENTS

1. SAFETY WARNINGS.....	3
2. INTENDED USE.....	6
3. WARNING SYMBOLS.....	7
4. PRODUCT COMPONENTS.....	8
5. TECHNICAL SPECIFICATIONS.....	9
6. CONTROLS AND FUNCTIONS	9
7. MATERIAL / PAINT SELECTION.....	9
8. ASSEMBLY.....	10
9. PRE-OPERATION.....	12
10. SPRAYING.....	15
11. CLEANING.....	18
12. TROUBLESHOOTING.....	24
13. MAINTENANCE & STORAGE.....	25
14. DISPOSAL INSTRUCTIONS.....	27
15. DECLARATION OF CONFORMITY... ..	28
16. WARRANTY.....	29
17. PRODUCT FAILURE.....	30
18. WARRANTY EXCLUSIONS.....	31

1. SAFETY WARNINGS

INSTRUCTIONS PERTAINING TO A RISK OF FIRE, ELECTRIC SHOCK, OR INJURY TO PERSONS

WARNING – When using tools, basic precautions should always be followed, including the following:

- a) **SAVE THESE INSTRUCTIONS**-To reduce the risks of fire or explosion, electrical shock and injury to persons, read and understand all instructions included in this manual. Be familiar with the controls and the proper usage of the equipment.
- b) **WARNING**-To reduce the risk of fire or explosion:
 - 1) Do not spray flammable or combustible materials near an open flame or sources of ignition such as cigarettes, motors, and electrical equipment.
 - 2) For units intended for use with only water-based materials-Do not spray or clean with flammable liquids. For use with water-based liquids only.
 - 3) For units intended for use with only water-based or mineral spirit-type materials with a minimum flash point of 21C°(69.8 F°) Do not spray on clean with liquids having a flash point less than 21C°(69.8 F°)
 - 4) Paint or solvent flowing through the equipment is able to result in static electricity. Static electricity creates a risk of fire or explosion in the presence of paint or solvent fumes. All parts of the spray system, including the pump, hose assemble, spray gun, and objects in and around the spray area shall be properly grounded to protect against static discharge and sparks. Use only conductive or grounded high-pressure airless paint sprayer hoses specified by the manufacturer.
 - 5) Verify that all containers and collection systems are grounded to prevent static discharge.
 - 6) Connect to a grounded outlet and use grounded extension cords. Do not use a 3 to 2 adapter.
 - 7) Do not use a paint or a solvent containing halogenated hydrocarbons. See operating instructions for examples of these types of materials.
 - 8) Keep spray area well ventilated. Keep a good supply of fresh air moving through the area. Keep pump assembly in a well ventilated area. Do not spray pump assembly.
 - 9) Do not smoke in the spray area.
 - 10) Do not operate light switches, engines, or similar spark producing products in the spray area.
 - 11) Keep area clean and free of paint or solvent containers, rags, and other flammable materials.
 - 12) Know the contents of the paints and solvents being sprayed. Read all Material safety Data Sheets (MSDS) and container labels provided with the paints and solvents. Follow the paint and solvent manufacturer's safety instructions.
 - 13) Fire extinguisher equipment shall be present and working.
- c) **WARNING**-To reduce the risk of skin injection.
 - 1) Do not aim the gun at, or spray any person or animal.
 - 2) Keep hands and other body parts away from the discharge. For example, do not try to stop leaks with any part of the body.
 - 3) Always use the nozzle tip guard. Do not spray without nozzle tip guard in place.
 - 4) Only use a nozzle tip specified by the manufacturer.
 - 5) Use caution when cleaning and changing nozzle tips. In the case where the nozzle tip clogs while spraying, follow the manufacturer's instructions for turning off the unit and relieving the pressure before removing the nozzle tip to clean.
 - 6) Do not leave the unit energized or under pressure while unattended. When the unit is not in use, turn off the unit and relieve the pressure in accordance with the manufacturer's instructions.
 - 7) High-pressure spray is able to inject toxins into the body and cause serious bodily injury. In the event that injection occurs, seek medical attention immediately.

- 8) Check hose and parts for signs of damage. Replace and damaged hoses of parts.
 - 9) This system is capable of producing 20.7Mpa. Only use replacement parts or accessories that are specified by the manufacturer and that are rated a minimum of 22.8Mpa.
 - 10) Always engage the trigger lock when not spraying. Verify the trigger lock is functioning properly.
 - 11) Verify that all connections are secure before operating the unit.
 - 12) Know how to stop the unit and bleed pressure quickly. Be thoroughly familiar with the controls.
- d) **WARNING**-To reduce the risk of injury.
- 1) Always wear appropriate gloves, eye protection, and a respirator or mask when painting.
 - 2) Do not operate or spray near children. Keep children away from equipment at all times.
 - 3) Do not overreach or stand on an unstable support. Keep effective footing and balance at all times.
 - 4) Stay alert and watch what you are doing.
 - 5) Do not operate the unit when fatigued or under the influence of drugs or alcohol.
 - 6) Do not kink or over-bend the hose.
 - 7) Do not expose the hose to temperatures or to pressures in excess of those specified by the manufacturer.
 - 8) Do not use the hose as a strength member to pull or lift the equipment.
 - 9) The Max. pressure of the air hose is 22.8Mpa, the normal pressure is 20.7Mpa
 - 10) The paint can be compatible: phenol aldehyde paint series, nitril paint series, alkyd paint series, epoxy resin paint series, oxidized rubber paint series, latex paint series, water soluble paint series. The paint should be put in shade and dry place.
 - 11) Be aware of any hazards presented by the material being sprayed and consult the markings on the container or information supplied by the manufacturer of the material to be sprayed, including requirements for the use of personal protective equipment.
 - 12) Do not spray any material there the hazard is not know.

Warning

The following warnings are for the setup, use, grounding, maintenance and repair of this equipment. The exclamation point symbol alerts you to a general warning and the hazard symbol refers to procedure-specific risks. Refer back to these warnings. Additional, product-specific warnings may be found throughout the body of this manual where applicable.

FIRE AND EXPLOSION HAZARD

Flammable fumes, such as solvent and paint fumes, in work area can ignite or explode. To help prevent fire and explosion:

- Use equipment only in well ventilated area.
- Eliminate all ignition sources; such as pilot lights, cigarettes, portable electric lamps, and plastic drop cloths (potential static arc).
- Sprayer generates sparks. When flammable liquid is used in or near the sprayer or for flushing or cleaning, keep sprayer at least 20 feet (6 m) away from explosive vapors.
- Keep work area free of debris, including solvent, rags and gasoline.
- Do not plug or unplug power cords or turn lights on or off when flammable fumes are present.
- Ground equipment and conductive objects in work area.
- If there is static sparking or you feel a shock, stop operation immediately. Do not use equipment until you identify and correct the problem.
- Keep a working fire extinguisher in the work area.

ELECTRIC SHOCK HAZARD

Improper grounding, setup, or usage of the system can cause electric shock.

- Turn off and disconnect power cord before servicing equipment.
- Use only grounded electrical outlets.
- Use only 3-wire extension cords.
- Ensure ground prongs are intact on sprayer and extension cords.
- Do not expose to rain. Store indoors.

SKIN INJECTION HAZARD

High-pressure fluid from gun, hose leaks, or ruptured components will pierce skin. This may look like just a cut, but it is a serious injury that can result in amputation. Get immediate surgical treatment.

- Do not point gun at anyone or at any part of the body.
- Do not put your hand over the spray tip.
- Do not stop or deflect leaks with your hand, body, glove, or rag.
- Engage trigger lock when not spraying.
- Follow Pressure Relief Procedure in this manual, when you stop spraying and before cleaning, checking, or servicing equipment.

EQUIPMENT MISUSE HAZARD

Misuse can cause death or serious injury.

- Do not exceed the maximum working pressure or temperature rating of the lowest rated system component. Read Technical Data in all equipment manuals.
- Use fluids and solvents that are compatible with equipment wetted parts. Read Technical Data in all equipment manuals. Read fluid and solvent manufacturer's warnings. For complete information about your material, request MSDS from distributor or retailer.
- Check equipment daily. Repair or replace worn or damaged parts immediately with manufactory replacement parts only.
- Do not alter or modify equipment.
- Use equipment only for its intended purpose. Call your distributor for information.
- Route hoses and cables away from traffic areas, sharp edges, moving parts, and hot surfaces.
- Do not kink or over bend hoses or use hoses to pull equipment.
- Comply with all applicable safety regulations.
- Keep children and animals away from work area.
- Do not operate the equipment when fatigued or under the influence of drugs or alcohol.

PRESSURIZED ALUMINUM PARTS HAZARD

Do not use trichloroethane, ethylene chloride, other halogenated hydrocarbon solvents or fluids containing such solvents in pressurized aluminum equipment.

Such use can cause serious chemical. Reaction and equipment rupture, and result in death, serious injury, and property damage.

BURN HAZARD

Equipment surfaces can become very hot during operation. To avoid severe burns, do not touch hot equipment. Wait until equipment has cooled completely.

MOVING PARTS HAZARD

Moving parts can pinch or amputate fingers and other body parts.

- Keep clear of moving parts.
- Do not operate equipment with protective guards or covers removed.
- Pressurized equipment can start without warning. Before checking, moving, or servicing equipment, follow the **Pressure Relief Procedure** in this manual. Disconnect power or air supply.

TOXIC FLUID OR FUMES HAZARD

Toxic fluids or fumes can cause serious injury or death if splashed in the eyes or on skin, inhaled, or swallowed.

- Read warnings to know the specific hazards of the fluids you are using.
- Store hazardous fluid in approved containers, and dispose of it according to applicable guidelines.

PERSONAL PROTECTIVE EQUIPMENT

You must wear appropriate protective equipment when operating, servicing, or when in the operating area of the equipment to help protect you from serious injury, including eye injury, inhalation of toxic fumes, burns, and hearing loss. This equipment includes but is not limited to:

- Protective eye wear
- Clothing and respirator as recommended by the fluid and solvent manufacturer
- Gloves
- Hearing protection

2. INTENDED USE

This machine can spray a variety of paints, oil base latex, primers, stains, preservatives and other non-abrasive materials, including non-flammable liquid fertilizers.







This pump should not be used with textured materials, block filler, or asphalt sealer.

- A) Forbidden use of machines which are not designed for potentially explosive atmospheres
- B) Use of electrostatic atomizing and spraying equipment with machines not specially designed for this equipment, because it may result in serious hazards for the operators
- C) Hazards resulting from contact with and/or breathing of toxic materials, gases, mists and vapors which may be created by operation of the machine. Such warnings shall also include such regarding the use of personal protective equipment and reminding the user to be aware of the recommendations of the coating material manufacturer;
- D) Surface temperatures of any part of the machine, reachable during normal operation, maintenance and servicing but not normally in contact with the human body, which can exceed 48°C or be less than 0°C.
- E) DO NOT aim or point gun or spray at any person or animal.;
- F) Please read and understand this entire manual before attempting to assemble, operate or install the product.
- G) Please make sure Plug into grounded outlet.;
- H) It is recommended to use the below coating section diagram to best select the proper tip size you intend to use for your particular spraying application. Please consult your local retailer if you are unsure of the proper tip size which should be used. DO NOT spray acids, corrosive materials, toxic chemicals, fertilizers or pesticides with this item.

Coating Selection						
Tip Hole Size (expressed as diameter, based on area of elliptical orifice)	Stains	Enamels	Oil-based primers and paints	Interior latex paints	Exterior latex paints	Acrylics
0.011 in. (0.28 mm)	X					
0.013 in. (0.33 mm)	X	X	X	X		
0.015 in. (0.38 mm)		X	X	X	X	
0.017 in. (0.43 mm)			X	X	X	X
0.019 in. (0.48 mm)					X	X

- I) To reduce your exposure to these chemicals & fire\explosion risk, work in a well-ventilated area and wear safety equipment, Such as respirator or dust mask specially designed to filter microscopic particles.;
- J) ALWAYS check air hoses for weak or worn connections before each use and make certain that all connections are secure.
- K) ALWAYS be aware of your work area surroundings and the people around the work area to ensure your safety.
- L) The Coating and auxiliary material is harmful for your health & environment So Reduce the quantity of coating and/or auxiliary materials at workplaces to a minimum

3. WARNING SYMBOLS

	read instruction manual.
	Always wear ear protection
	Always wear goggles
	Always wear a breathing mask
	Warning symbol
	Class II product

4. PRODUCT COMPONENTS



1. Spray Hose
2. Trigger Guard
3. Trigger
4. Nozzle Guard
5. Spray Tip
6. Spray Gun
7. Spray Gun Handle
8. Lance
9. Carry Handle

10. ON/OFF Switch
11. Prime/Spray Switch
12. Return Hose Inlet Port
13. Return Hose
14. Stand
15. Suction Hose Filter
16. Suction Hose
17. Suction Hose Inlet Port
18. Spray Hose Outlet Port

Contents of Box

- 1 x Airless Spray Station 1010W
- 1 x Spray Gun
- 1 x Spray Hose 7.5m
- 2 x Hex Wrench
- 1 x Spray Tip
- 1 x Lance
- 1 x Instruction Manual

5. TECHNICAL SPECIFICATIONS

Voltage and frequency	230-240 V~ 50 Hz
Power	1010 W
Flow rate	1.5 L/min
Maximum pressure	22.7MPa
Net Weight	7.2 kg
Temperature	Min. 10°C/ Max 40°C
IP(Ingress Protection)	IPX0
Insulation class	II
Measured sound pressure level	LpA: 84.7dB(A) K=3dB(A)
Measured sound power level	LwA: 93.6dB(A) K=3dB(A)
Guaranteed sound power level	110dB(A)

6. CONTROLS AND FUNCTIONS

- **ON/OFF Switch (10):**
The ON/OFF Switch (10) turns the power to the sprayer ON (“I”) and OFF (0”)
- **Prime/Spray Switch (11):**
The Prime/Spray Switch (11) directs fluid to the Spray Hose (1) when set to SPRAY or to the Return Hose (13) when set to PRIME. The Prime/Spray Knob is also used to relieve pressure built up in the Spray Hose (refer to Pressure Relief Procedure).
- **Pressure Gauge (8):**
Optional accessory that identifies the amount of force the pump uses to push the fluid through the Spray Gun (6).
- **Suction Hose (16):**
Fluid is drawn through the Suction Hose (16) into the pump.
- **Return Hose (13):**
Fluid is sent back through the Return Hose (13) to the original container when Prime/Spray Switch (10) is in PRIME position.
- **Suction Hose Filter (1 5):**
Strains the spray material to prevent the system from being clogged.
- **Spray Gun (6):**
Controls the delivery of the fluid being pumped.
- **Spray Hose (1):**
Connects the Spray Gun (6) to the pump.
- **Lance (1 9):**
Optional accessory that can be attached to the end of the Spray Gun (6) to spray hard to reach areas.

7. MATERIAL / PAINT SELECTION



Do not use textured wall paints or coatings as this will block the spray gun tip and damage internal components of the Airless Spray Station.

Although a large number of paints and materials can be sprayed, some cannot. Please check the manufacturers’ recommendations before purchasing paint.

MATERIALS WHICH CAN BE USED:

Recommended for spraying the following materials:

- Water-based paints
- Wood preservatives
- Oil-based paints
- Primers
- Enamel paint
- Wash primer
- Varnish
- Oil
- Stains

MATERIALS WHICH CANNOT BE USED:

The Airless Spray Station CANNOT be used for the following materials:

- Paints and lacquers containing heavily abrasive components such as:
 - Exterior textured wall paints
 - Glazes,
 - Lyes
 - Acids
 - Dispersion paints
 - Caustic and Alkaline substances
 - Textured coatings
 - Emulsion paints
- Silicate paints.
- Flammable materials.
- Asphalt sealer.
- Block filler.
- Pesticides
- Flammable liquid fertilizers

The use of these materials will cause premature wear and block the spray tip and will void warranty. To obtain the best results from your Airless Spray Station, **PLEASE READ THE INSTRUCTION MANUAL CAREFULLY BEFORE USE.**

8. ASSEMBLY



WARNING! Ensure the machine is disconnected from the power supply before performing any of the following operations.

Spray Hose & Spray Gun Connection

1. Thread the Spray Hose (1) and tighten with supplied wrench (Fig .2 a).Do not overtighten.
2. Thread the other end of the Spray Hose (1) to the Spray Gun (6) and tighten with the supplied wrench (Fig.2b). Do not overtighten.

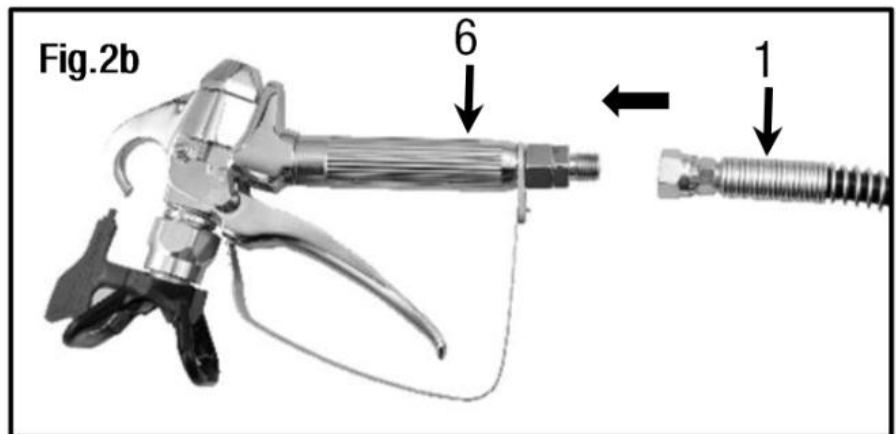

Connecting Lance to Spray Gun

The Lance (19) is an optional accessory. The Spray Gun (6) can be used with or without the Lance (19) accessory. The Lance (19) can be used to spray hard to reach areas.

1. Remove the Nozzle Guard (4) and Spray Tip (5) from the Spray Gun (6) (Fig.3a).
2. Thread the Lance (19) onto the end tip of the Spray Gun (6) and tighten with supplied wrench (Fig.3a).

Do not overtighten (Fig.3b).

3. Thread the Nozzle Guard (4) with the Spray Tip (5) onto the Lance (19) and tighten with the supplied wrench. Do not overtighten (Fig.3b).

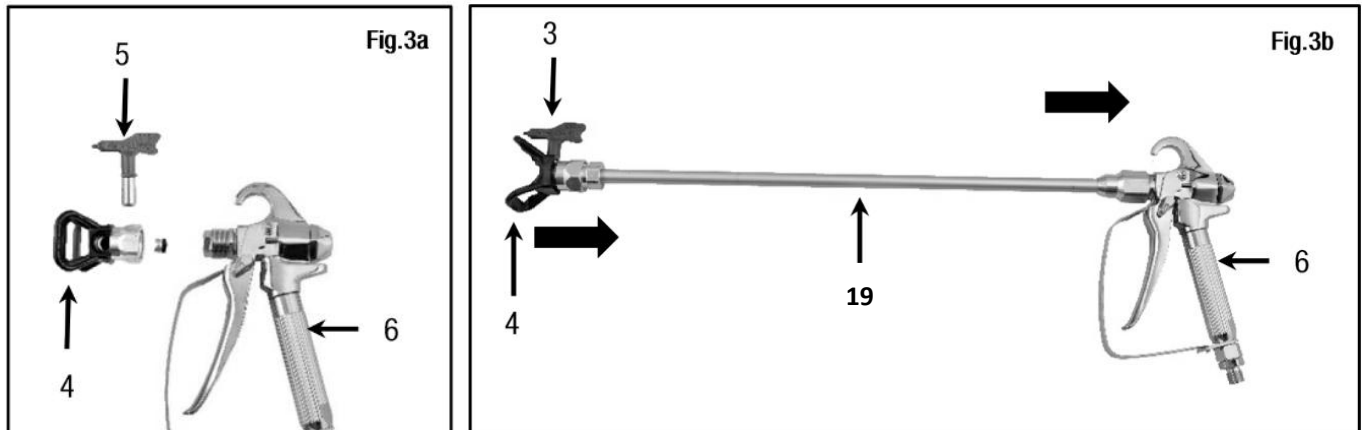

Adding lubricant

Before starting the machine for the first time, add lubricating oil to it. Tilt it at 45 ° and locate the lubrication hole on its front face. Add lubricating oil to the piston rod (3 to 5 drops). Adding 3 to 5 drops before each start can increase the life of the machine.

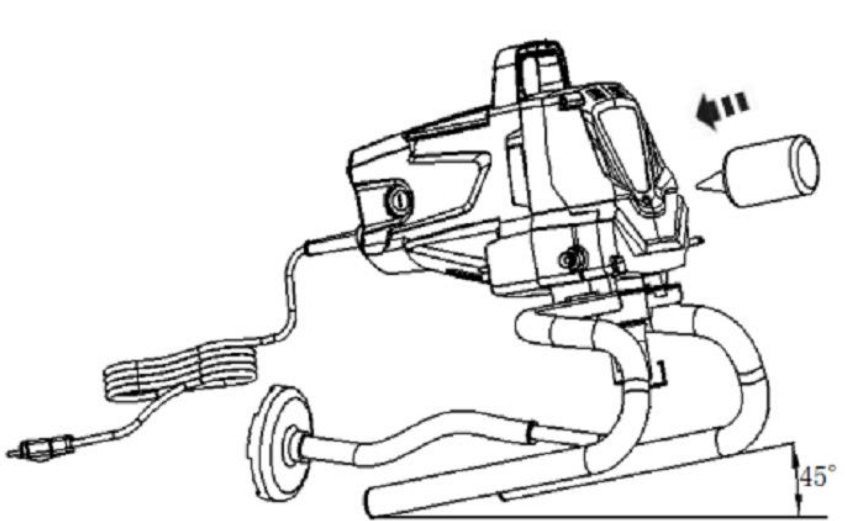

9. PRE-OPERATION

⚠ WARNING! Ensure the machine is disconnected from the power supply before performing any of the following operations. Visually inspect the hoses for damage before use.

This section contains instructions that will be repeated throughout this manual. Read and understand this section before using the equipment.

Locking the Spray Gun Trigger

⚠ The spray gun Trigger (3) should be locked prior to preparing the spray station to ensure the Trigger (3) is not accidentally pressed.

Lock the spray gun Trigger (3) whenever instructed.

1. To LOCK the Trigger (3), rotate the Trigger Locking Switch backwards towards the rear end of the spray gun (6) until it stops (Fig.4a).
2. To UNLOCK the Trigger (3), rotate the Trigger Locking Switch forward towards the Trigger Guard (2) until it stops (Fig.4b).

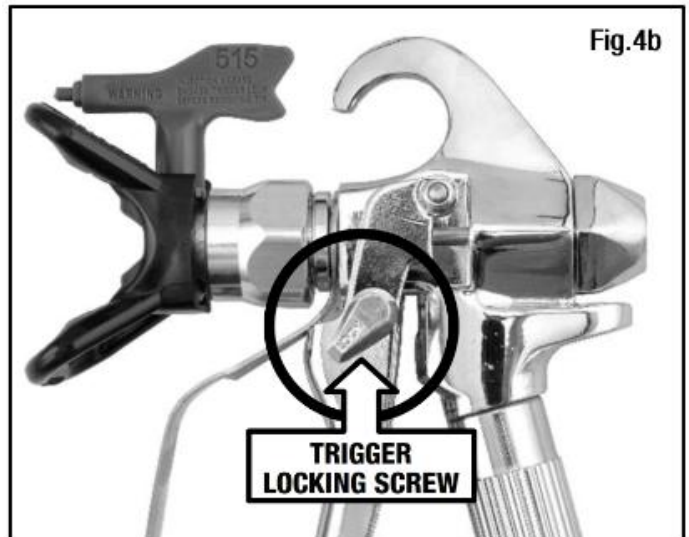
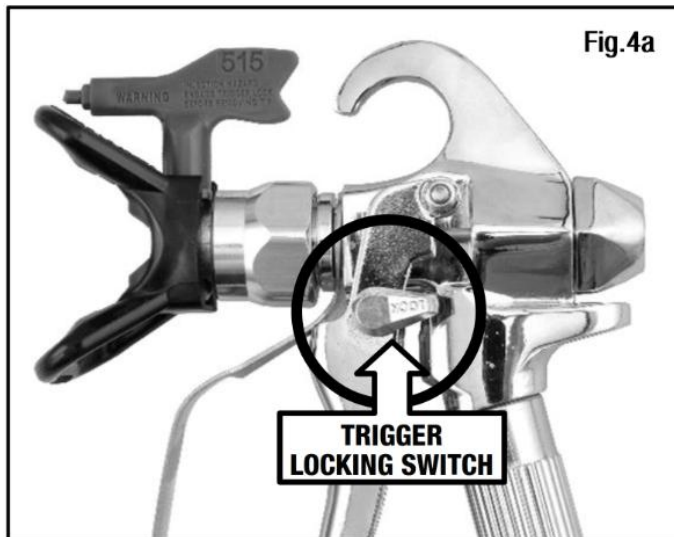

Pressure Relief Procedure

⚠ Always follow the Pressure Relief Procedure when shutting the machine off for any purpose. This procedure is used to relieve pressure from the Spray Hose (1). Failure to do so may result in serious injury.

⚠ Never aim the Spray Gun (6) towards at any part of your body, other people or animals. Perform the Pressure Relief Procedure whenever instructed in this manual.

1. Lock the spray gun Trigger (3) by rotating the Trigger Locking Switch towards the rear end of the Spray Gun (6) (Fig.5a).
2. Turn the Prime/Spray Switch (11) to the "PRIME" position by turning the Prime/Spray Switch (11) upwards (Fig.5b).
3. Turn OFF the machine by pressing "O" on the On/Off Switch(10) (Fig.5c).
4. Unlock the spray gun Trigger (3) by rotating the Trigger Locking Switch towards the Trigger Guard (2) until it stops (Fig.5d). Then briefly pull the spray gun Trigger (3) into the side of a waste bucket to fully relieve pressure from the system.
5. Lock the spray gun Trigger (3) (Fig.5a)

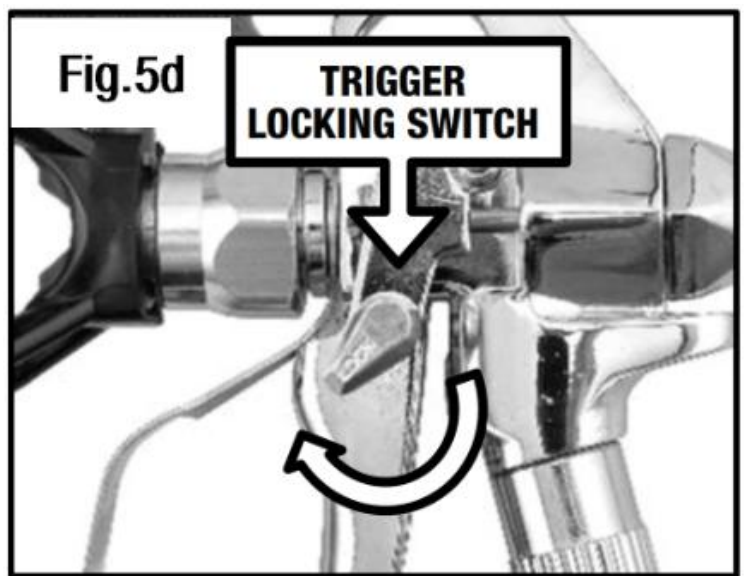
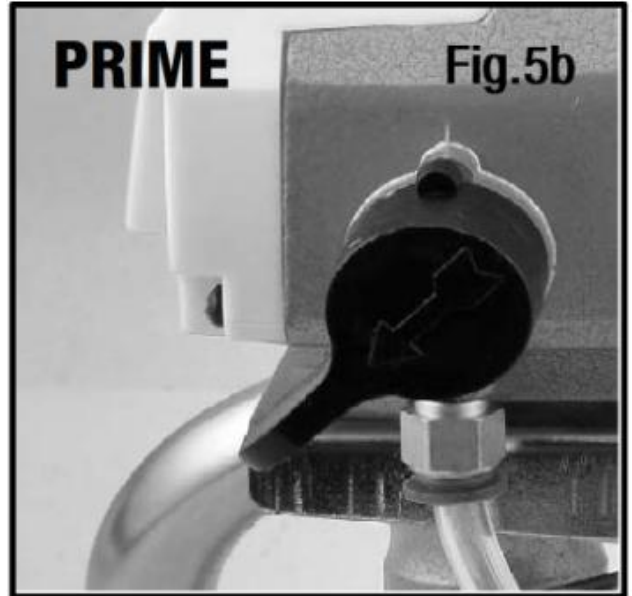
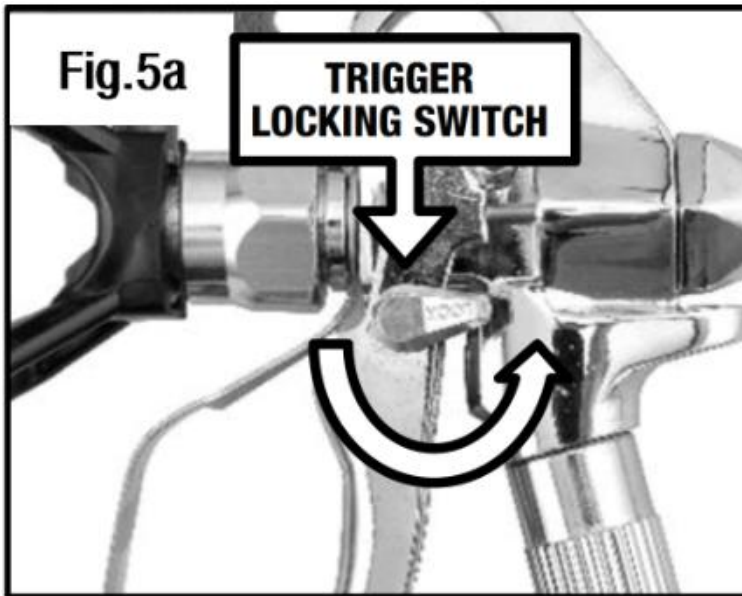

Priming the Pump

1. Separate the Suction Hose (16) from the Return Hose (13), then:
 - Place the Suction Hose (16) inside a full container of paint(Fig . 6a).
 - Place the Return Hose (13) into a waste container (Fig.6a).
2. Set the Prime/Spray Switch (11) to “PRIME” position (Fig.6b).
3. Turn ON the machine by pressing “I” on the On/Off Switch (13) (Fig.6c).
Allow pump to run for approx. 60 seconds until you see a steady stream of paint coming out of the Return Hose and into the waste container.
5. Set the Prime/Spray Switch (11) to “SPRAY” position (Fig.6d),
6. Wait for the Airless Spray Station to cut out after a few moments. If the Airless Spray Station does not shut off automatically, repeat steps 2 to 5.
7. Place the Return Hose (13) back into the container of paint and clip the Return Hose (13) and Suction Hose (16) together (Fig.6e).

Recommendation: It is good practice to perform the steps on this page using water to familiarize yourself with the function of the unit as well as to ensure the unit is set up properly.

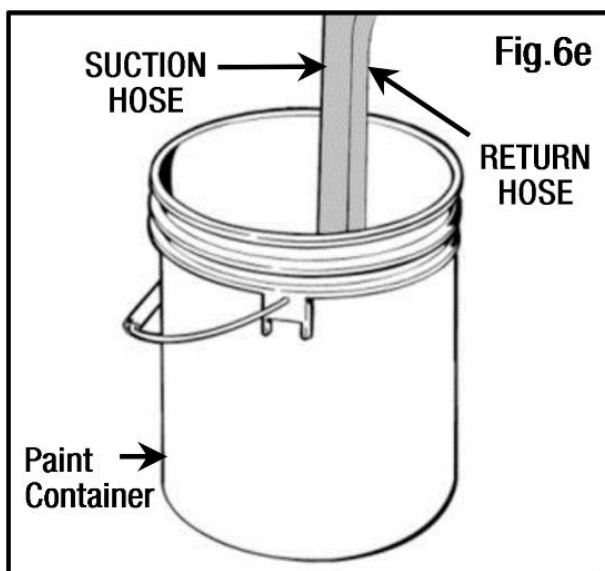
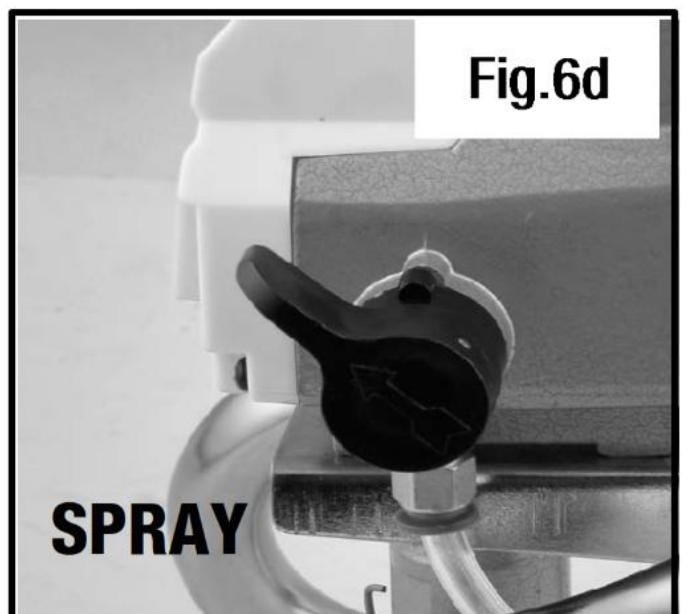
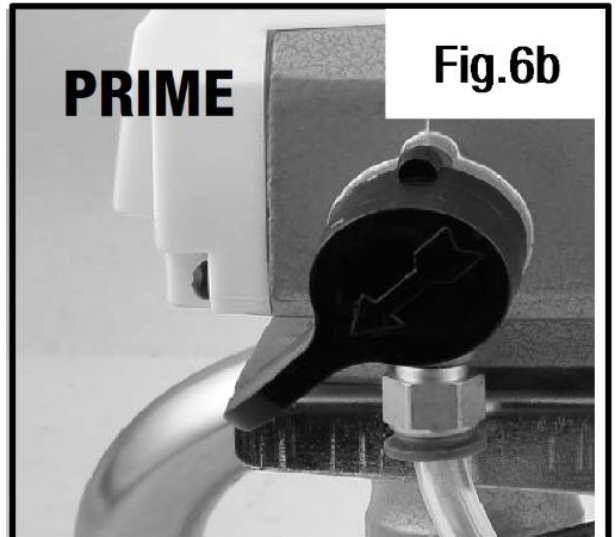
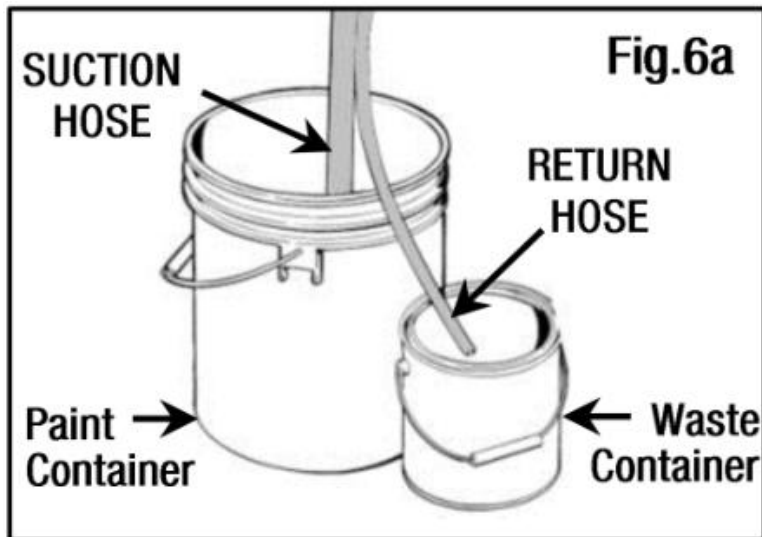

10. SPRAYING

! When operating the paint sprayer, appropriate personal protective equipment should be worn, such as protective goggles and masks. Choose a suitable spraying environment according to the needs, ensure good ventilation, and avoid the harm of paint volatiles to human health and the environment.

Spraying Procedure.

NOTE: Ensure the Airless Spray Station has been properly primed BEFORE commencing spraying operations. Refer to “Priming the Pump” instructions.

1. Ensure the Spray Tip (5) is rotated forward to the spray position with the arrow on the tip facing forward (Fig.7a).
2. Perform “Pressure Relief Procedure”.
3. Turn ON the machine by pressing “1” on the On/Off Switch (13) (Fig.7b).
4. Unlock the Spray Gun Trigger (3) (Fig.7c).
5. Set the Prime/Spray Switch (11) to “SPRAY” position (Fig.7d).
6. Stand about 30cm away from area to be sprayed and maintain this distance (Fig.7e). Pull the spray gun Trigger (3) to start spraying.

NOTE: The motor will cycle ON and OFF while spraying to regulate pressure. This is normal.

! **IMPORTANT!** When finished spraying, perform Pressure Relief Procedure.

! **IMPORTANT!** If you have not finished painting with your airless sprayer and want to take a short break (30-60 minutes), do not leave paint sitting inside the pump. Follow the cleaning instructions to prevent paint from drying inside the pump and hose. Once you're ready to begin work again, simply follow the Spraying Procedures. Once properly primed again, aim the spray gun into a waste bucket and allow 30 seconds for any leftover cleaning solution to be flushed out of the system. Then resume painting as normal.

IMPORTANT! Mineral Turpentine **SHOULD NOT** be mixed with water at any stage during the cleaning process.

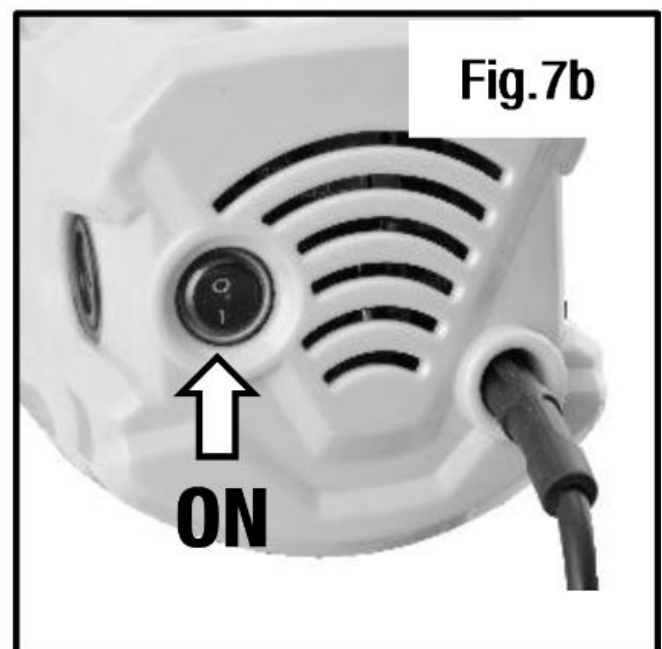
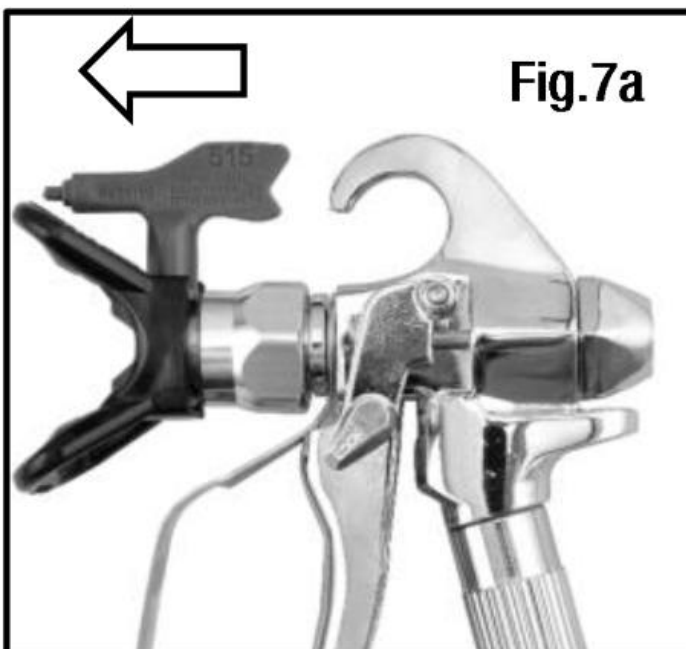

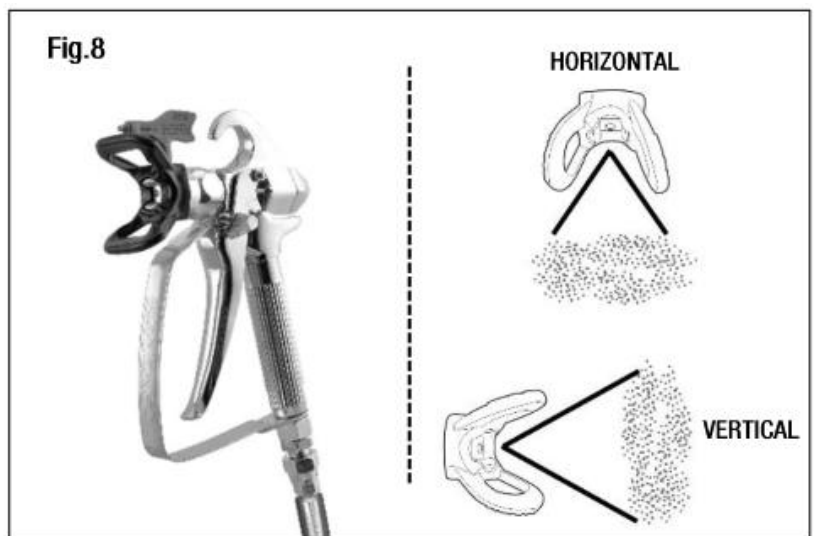
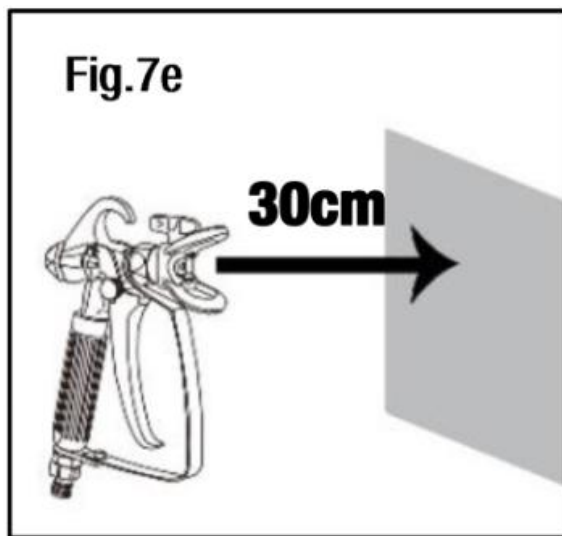
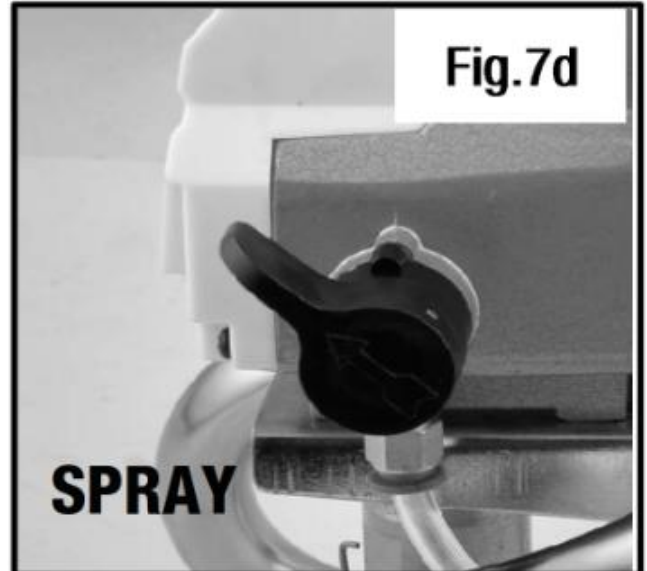
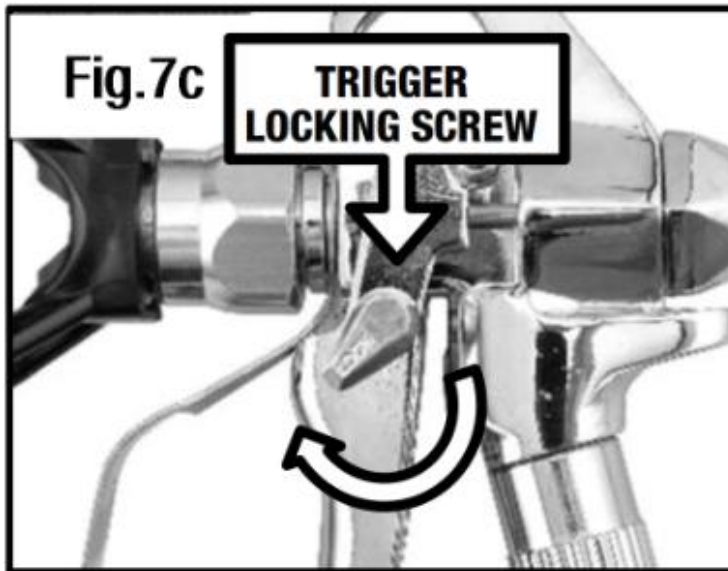

Test Spray Settings

NOTE: Ensure you follow the “Spraying Procedure” instructions before testing the spraying settings of the Airless Spray Station.

Aligning Spray

1. Follow the “Pressure Relief Procedure” instructions
2. Rotate the Nozzle Guard (4) to match the direction of the preferred spray pattern (Fig.8).

Spraying Technique

1. Move the Spray Gun (6) with the entire arm, not by flexing the wrist. This will keep the Spray Gun (6) at right angles to the surface, keeping the pattern even (Fig.9a)
2. Pull the spray gun Trigger (3) after starting the stroke, and release the Trigger (3) before ending the stroke. The Spray Gun (6) should be moving when the Trigger (3) is pulled and released (Fig.9b).

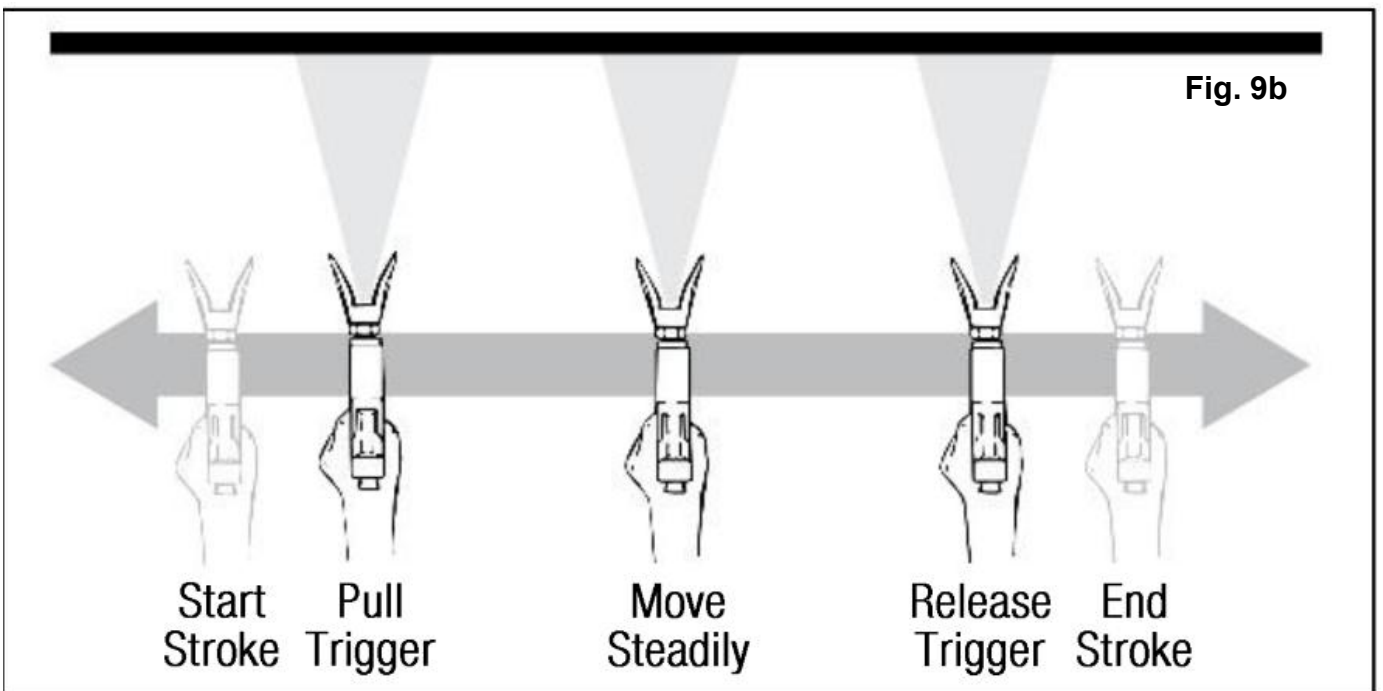
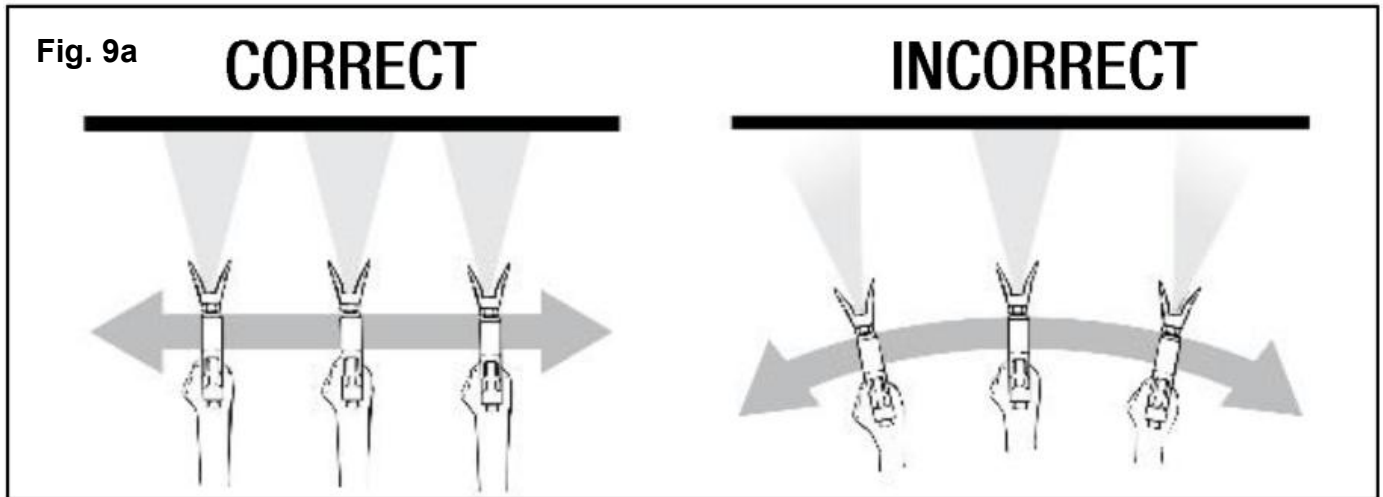

3. Keep the Spray Gun (6) perpendicular to the surface, so spray distance is consistent (Fig.9c).
4. Overlap your strokes by 30% to ensure even coverage (Fig.9d).

HINTS:

- Do not spray outdoors on a windy day as the results may be unsatisfactory.
- Only apply one coat at a time, always allow a coat to completely dry before adding another coat.
- Avoid stopping and starting as this can lead to a patchy finish, It is best to start spraying outside the surface to be sprayed and avoid stopping in the middle of the surface, continue just past the opposite edge

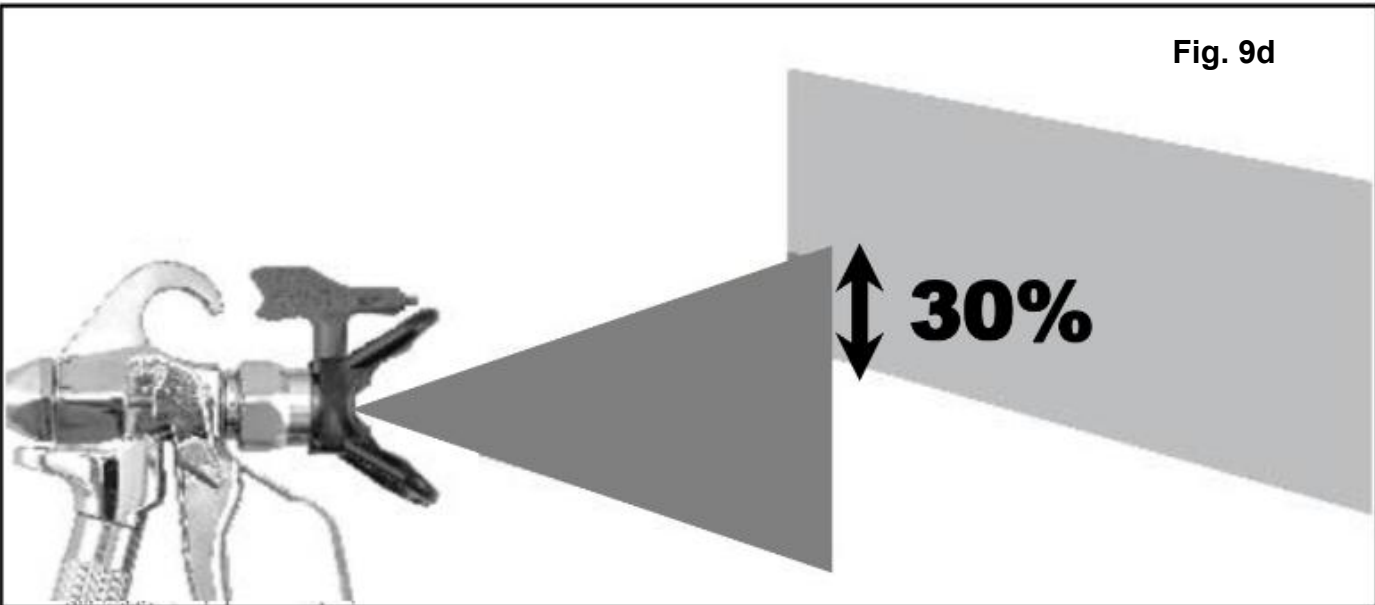
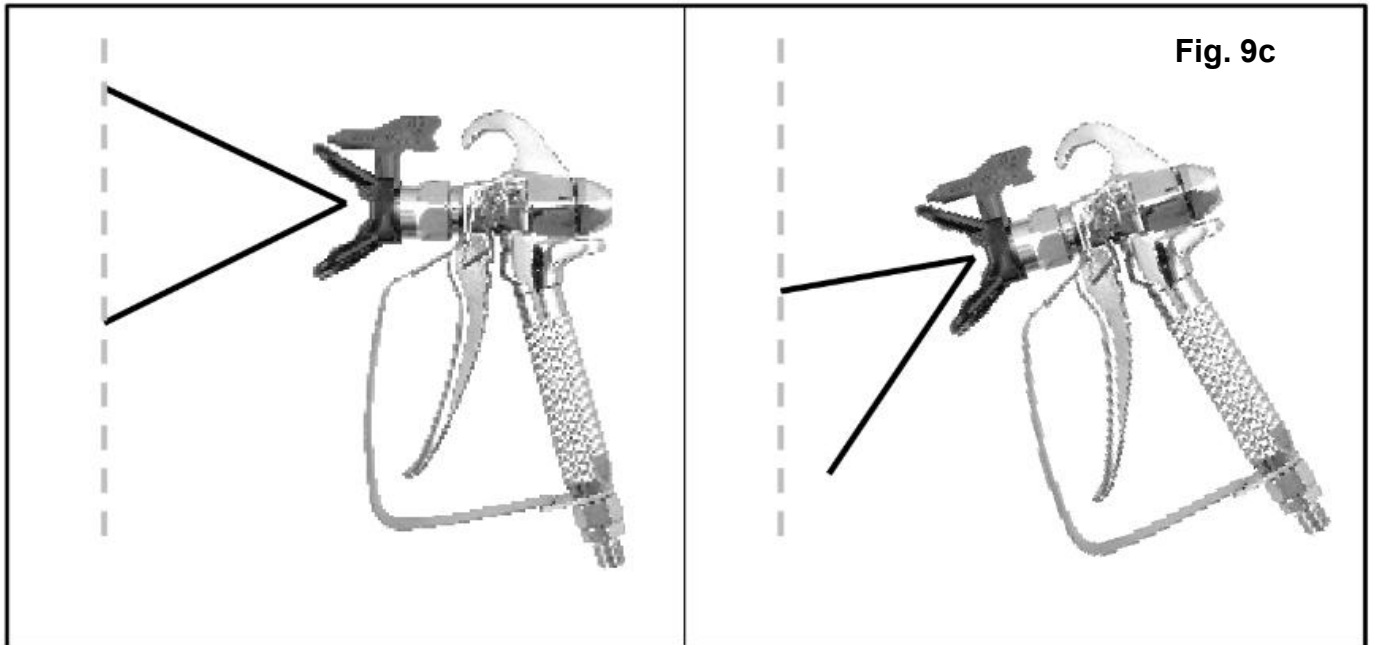

11. CLEANING

Select Cleaning Solution

For WATER-BASED material (e.g. acrylic paint):

- Use ONLY water when performing the cleaning procedure.
- **WARNING!** Use of a solvent-based cleaning materials on water-based paints will result in a new substance that will be extremely difficult to clean.
- We recommend the use of 10-15 litres of water when performing the cleaning procedure.

For OIL-BASED material (e.g. enamel paint, lacquer):

- Use ONLY the appropriate cleaning solution. Read the cleaning instructions printed on the coating material's label to determine which cleaning material you need.
- The following solvent-based cleaning products are safe to use in the airless spray station:
 - Mineral Turpentine
 - Paint Thinner
- **NOTE:** Mineral Turpentine **SHOULD NOT** be mixed with water at any stage during the cleaning process.

- We recommend 1 -2 litres of the appropriate solvent-based cleaner when performing cleaning procedure

Cleaning the Unit



IMPORTANT! The cleaning process must be followed immediately after use to prevent paint from drying inside the pump and hose. Failure to follow the cleaning instructions promptly may permanently seize the paint sprayer and automatically void the warranty.

1. Set the Prime/Spray Switch (11) to the “PRIME” position (Fig.10a).
 2. Place the Suction Hose (16) into a bucket of appropriate cleaning solution. Place the Return Hose (13) into an empty bucket (Fig.10b).
 3. Turn ON the machine by pressing “I” on the On/Off Switch (10) (Fig.10c).
- Check the Return Hose (13) and wait for a constant stream of cleaning solution to pass out of it.
4. Set the Prime/Spray Switch “SPRAY” position (Fig.10d).
 5. Aim the Spray Gun (6) into an empty bucket, then squeeze and hold the Trigger (3) until most of the paint is removed from the Spray Hose (1),.
 6. Lock the spray gun Trigger (3) (Fig.10f).
 7. Rotate the Spray Tip (5) 180° towards the Spray Gun Handle(7) (Fig,10g).
 8. Unlock the spray gun Trigger (3) and hold the Trigger (3) to spray the cleaning solution through the system (Fig.10h). Continue spraying until only cleaning solution is ejected from the Spray Tip (5). Add more cleaning solution if all the paint has not been removed.
- NOTE: If the cleaning solution bucket becomes cloudy with paint during this cleaning process, skip to section “Cleaning the Suction Hose Filter”. Once the Suction Hose Filter (15) and Spray Hose (1) are clean, re-assemble them and repeat steps 4 to 8 in this section.
9. Set the Prime/Spray Switch (11) to the “PRIME” position (Fig. 10i).
 10. Switch OFF the machine by pressing “O” on the On/Off Switch (10)(Fig.10j).

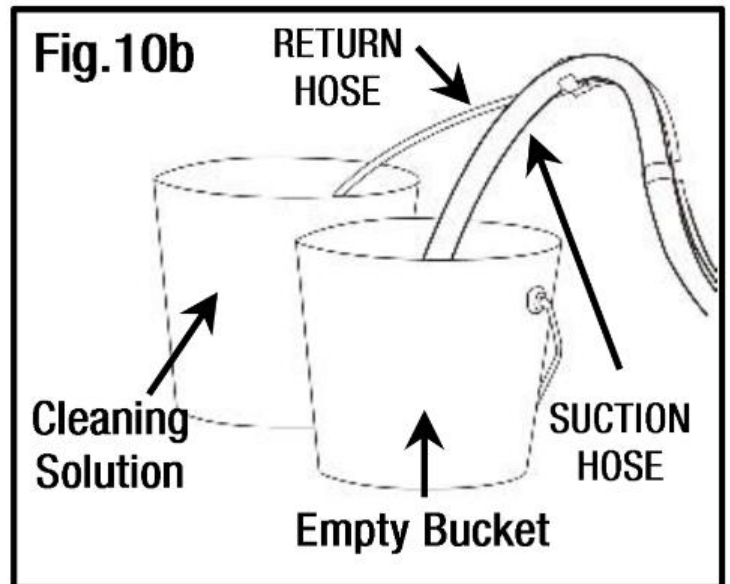
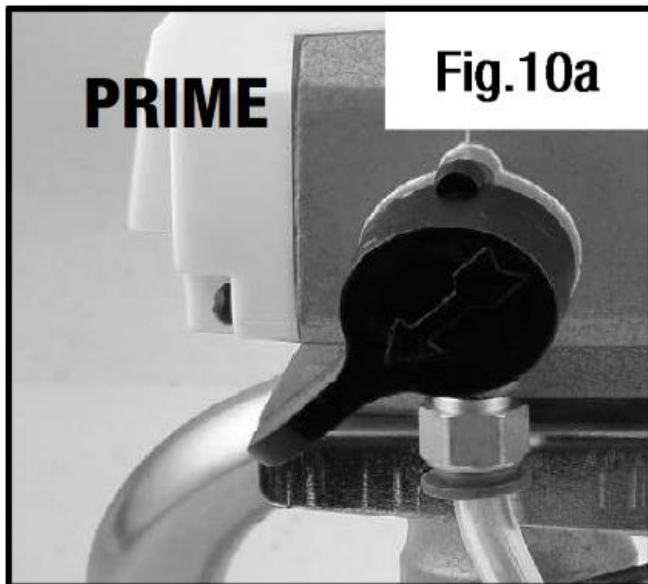

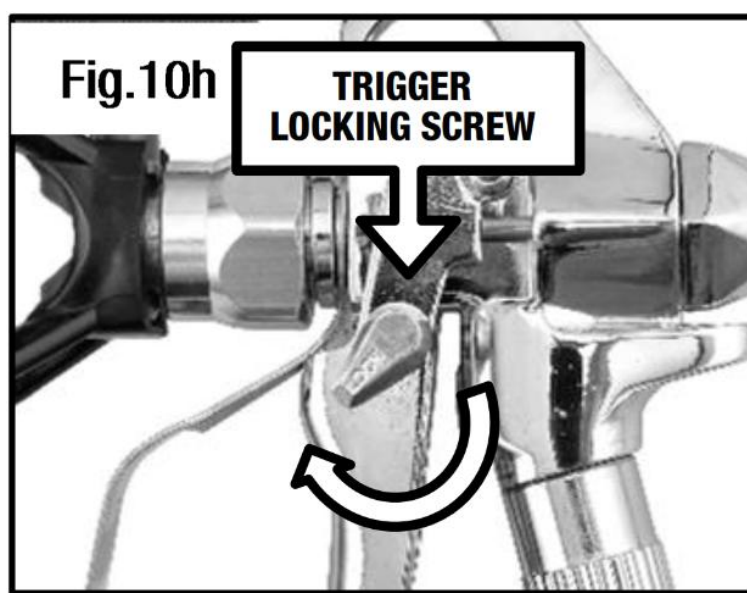
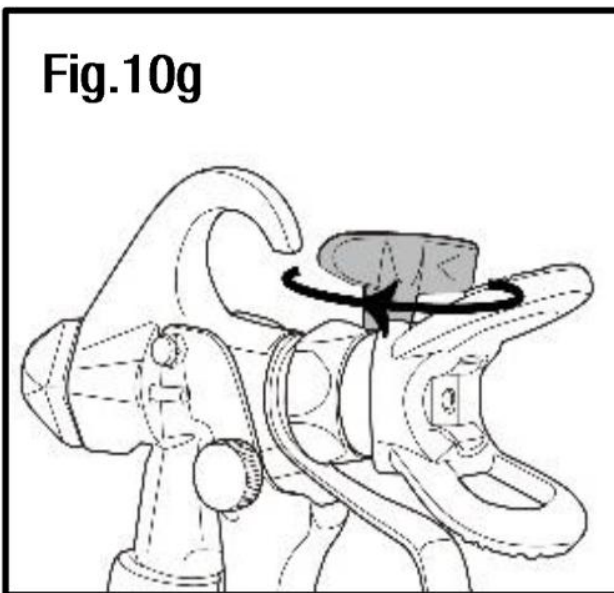
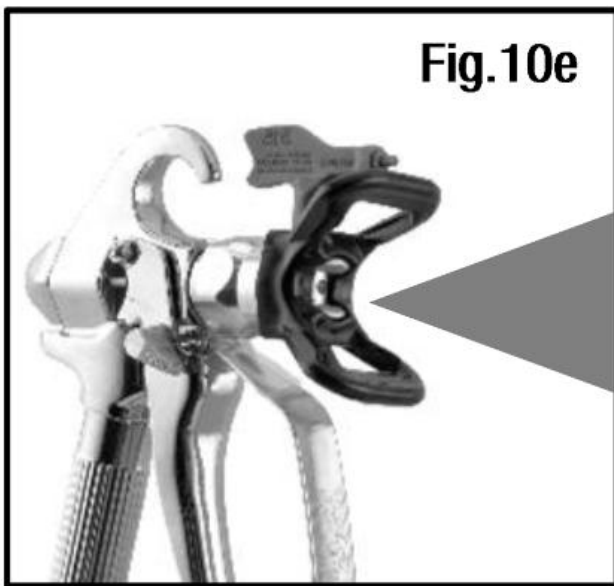
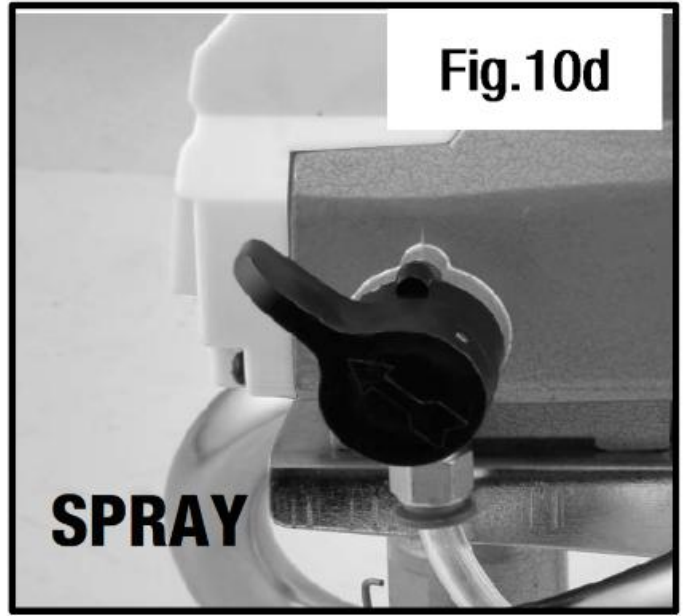
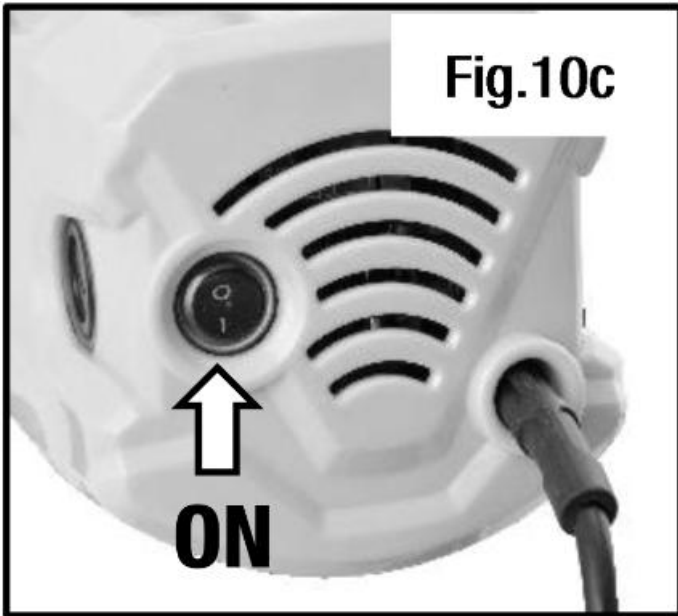

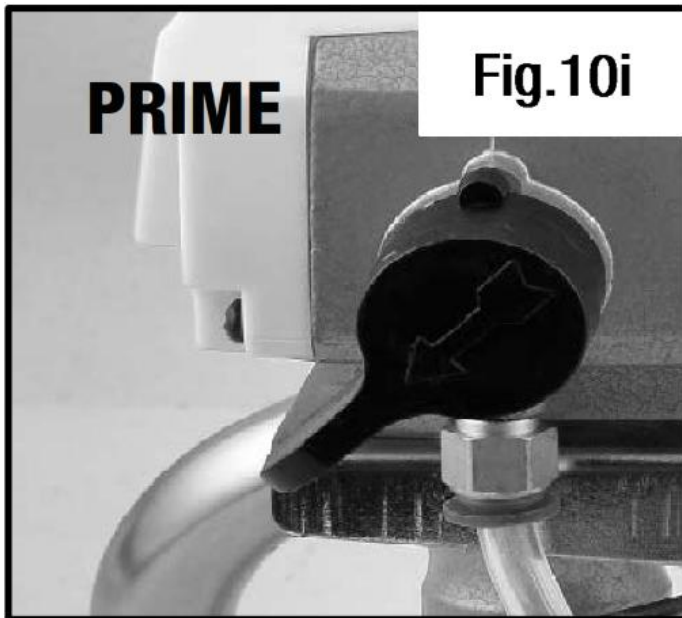

Cleaning the Suction Hose Filter

! **IMPORTANT!** The cleaning process must be followed immediately after use to prevent paint from drying inside the pump and hose. Failure to follow this instruction may permanently seize the paint sprayer and automatically void the warranty.

1. Unscrew the Suction Hose Filter (15) from the Suction Hose (16) (Fig.11a).
2. Clean the Suction Hose Filter (15) with the appropriate cleaning solution(Fig.11 b).
3. Thread the Suction Hose Filter (15) back onto the Suction Hose (16) once it has also been cleaned.

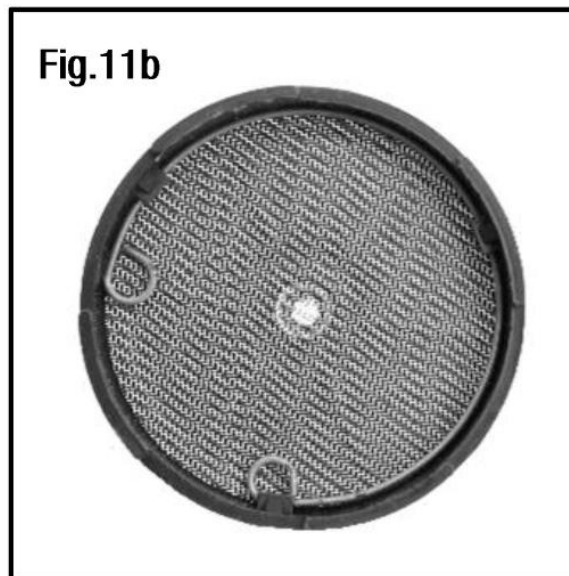

Cleaning the Spray Gun

IMPORTANT! The cleaning process must be followed immediately after use to prevent paint from drying inside the pump and hose. Failure to follow this instruction may permanently seize the paint sprayer and automatically void the warranty.

! **WARNING!** Ensure the unit is switched OFF and the Pressure Release Procedure has been performed.

1. Remove the Spray Gun (6) from the Spray Hose (1) by loosening the nut with the supplied wrench (Fig.1 2a).
 2. Remove the Nozzle Guard (4) and Spray Tip (5) from the Spray Gun (6) by loosening the nut. Once the guard assembly has been removed, pull the Spray Tip (5) out (Fig.12b).
- NOTE!** A small spacer and washer are used to locate the Spray Tip(5) within the Nozzle Guard (4). Be careful not to lose these components when the Nozzle Guard (4) is removed (Fig,12c).

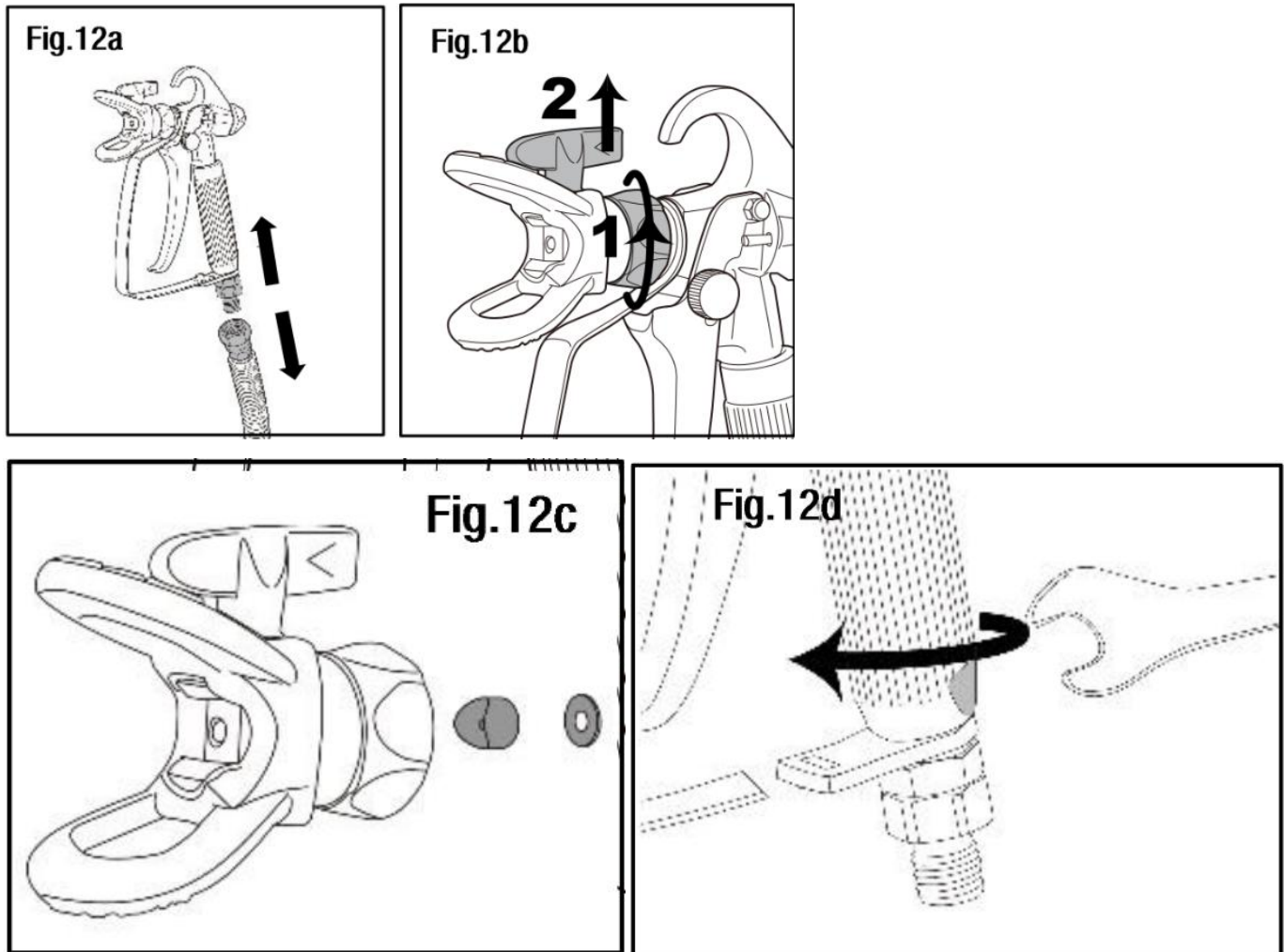

3. Unhook the Trigger Guard (2) from the Spray Gun Handle (7).
 4. While holding the upper body of the Spray Gun (6), loosen the Spray Gun Handle (7) using a wrench over the grooves located on the bottom part of the Spray Gun Handle (7). Rotate anti-clockwise until the Spray Gun Handle (7) can be completely removed (Fig.1 2d).
- TIP: Using a shifter or bench vice to hold the upper body of the Spray Gun (6) will make this step much easier.
5. Remove the mesh filter from the Handle (7) and clean all components in the cleaning solution (Fig.12e).
 6. If the Spray Tip (5) is blocked, use the cleaning pin by inserting it into the Spray Tip (5) (Fig.1 2f).
 7. To clean the mesh filter, unscrew either cap end by turning anti-clockwise. Once unscrewed, remove the cap and pull the other cap and spring out of the mesh filter sleeve. Use the cleaning brush to scrub the inside of the mesh filter (Fig12g).
- NOTE:** After cleaning, inspect the condition of the mesh filter. If the mesh filter is clogged with dried paint, has started fraying or has deformed out of shape, it will need to be replaced.
8. To re-assemble the Spray Gun (6), follow the procedures above in reverse.

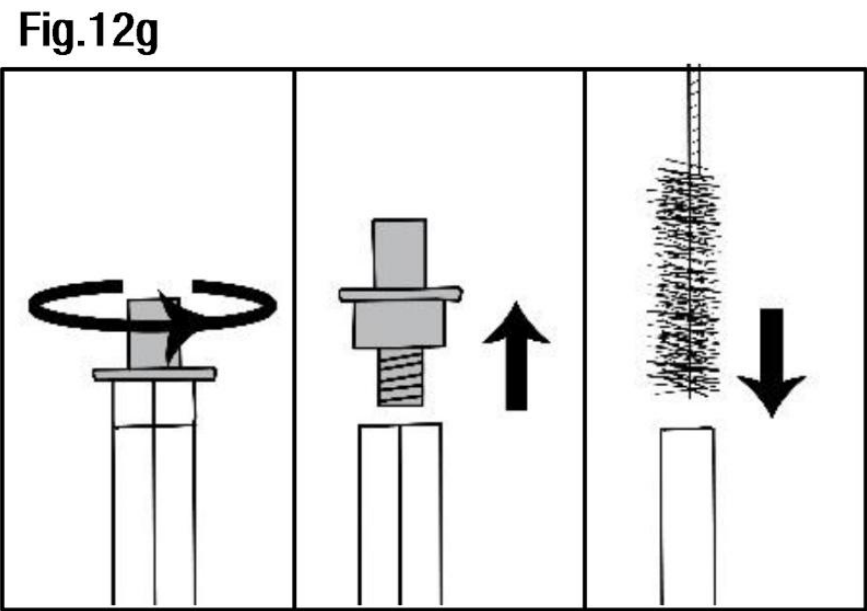
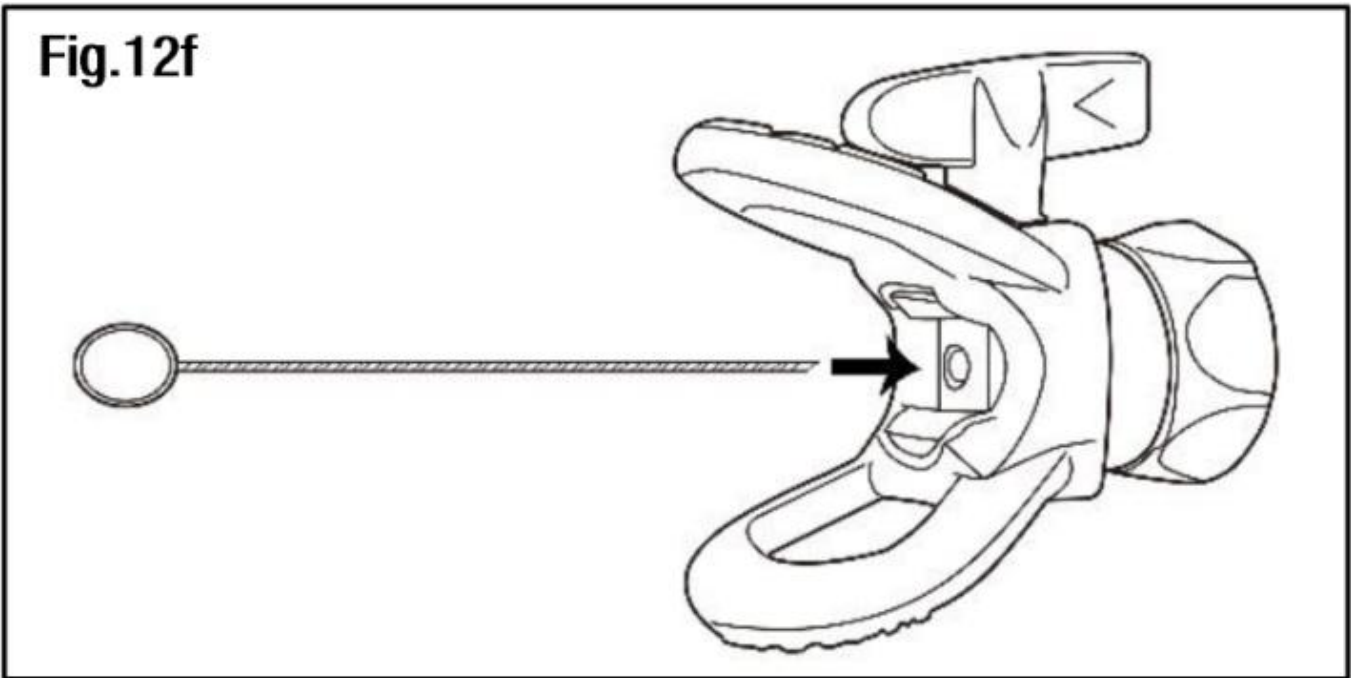
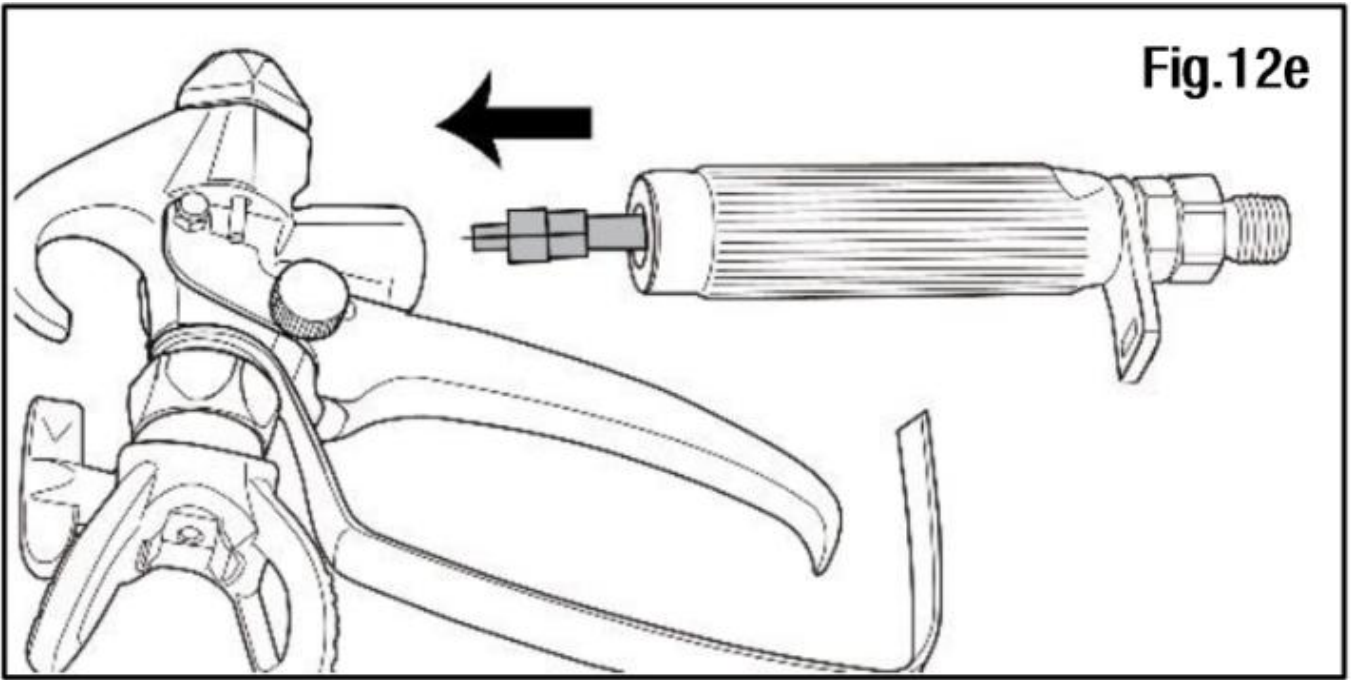

12. TROUBLESHOOTING

PROBLEM	POSSIBLE CAUSES	SUGGESTED SOLUTIONS
The sprayer does not turn ON.	The mains power lead is not plugged in.	Plug the mains power lead into a mains power outlet.
	No voltage is coming from the mains power outlet.	Properly test the power supply voltage.
	The ON/OFF Switch (10) is set to OFF.	Turn the ON/OFF Switch (10) to ON.
	The extension cord is damaged or has too low capacity.	Replace the extension cord with a suitable voltage.
Little or no material flow.	Spray Tip (5) is clogged.	Clean Spray Tip (5) using cleaning pin.
	Suction Hose (16) is clogged.	Clean Suction Hose (16).
	Suction Hose (16) is loose at the Suction Hose inlet Port.	Clean the Suction Hose (16) connections and tighten securely.
	Suction Hose Filter (15) clogged.	Clean or replace Suction Hose Filter (15). Use the appropriate cleaning solution depending on the material used
The Spray Tip leaks	The Nozzle Guard (4) nut is loose.	Tighten the Nozzle Guard (4) nut.
	Spray Tip (5) was assembled incorrectly,	Remove Spray Tip (5) and assemble correctly.
	Spray Tip (5) is worn.	Replace the Spray Tip (5).
Atomization is too coarse.	Spray Tip (5) and Nozzle Guard (4) clogged.	Clean.
	Suction Hose Filter (15) clogged.	Clean or replace.
Material leaking.	Nozzle Guard (4) is loose.	Tighten the Nozzle Guard (4).
	Spray Tip (5) is worn.	Replace the Spray Tip (5).
	Seal inside the Nozzle Guard (4) worn.	Replace the seal. Contact After Sales Support.
	Material building up inside Spray Tip (5) and Nozzle Guard (4).	Clean using the appropriate cleaning solution depending on the material used
Pattern runs or sags.	Applying too much material.	Increase movement of Spray Gun (6).
Too much over-spray.	Gun too far from spray object.	Reduce distance.
Pattern is very light and blotchy	Moving the Spray Gun (6) too fast.	Decrease movement of Spray Gun (6).
Spluttering paint.	Air bubbles in the Return Hose (13).	Perform "Priming the Pump" steps
Suction Hose (11) not sucking up water when cleaning the unit.	Lack of pressure.	Using the appropriate cleaning solution in place of material, perform the "Priming the Pump" steps

The paint pattern is tailing.	The spray gun Mesh Filter, the Spray Tip (5), or the Suction Hose Filter (15) is clogged.	Clean spray gun Mesh Filter, the Spray Tip (5), and the Suction Hose Filter (15).
	The Suction Hose (16) is loose at the Suction Hose Inlet Port (17).	Re-adjust the Suction Hose (16) to the Suction Hose Inlet Port(17).
	The Spray Tip (5) is worn.	Replace the Spray Tip (5).
	The paint is too thick.	Thin the paint according to the manufacturers instructions.

13. MAINTENANCE & STORAGE

Assembling the Spray lip & Nozzle Guard to Spray Gun

NOTE: The Spray Gun (6) comes assembled from the factory. If the Spray Gun (6) has been disassembled for cleaning, follow the steps below to re-assemble.

1. Insert the mesh filter into the Handle (7) and align the Handle (7) with the upper body of the Spray Gun(6) (Fig.13a).
2. While holding the upper body of the Spray Gun (6), tighten the Handle (7) using the supplied wrench (Fig,1 3b).
3. Hook the bottom edge of the Trigger Guard (2) into the hole in the Handle.
4. Ensure the small spacer and washer that locate the Spray Tip (5) are inserted in the Nozzle Guard (4) (Fig.13c).
5. Place Trigger Guard (2) over the end of Spray Gun (step 1) and insert Spray Tip (5) into the Trigger Guard (step 2) (Fig.13d). Make sure that the Spray Tip (5) is rotated forward to the spray position with the arrow on the tip facing forward.
6. Tighten the retaining nut (Fig.13e),

⚠ WARNING! Do not spray without the Spray Tip (5) and Nozzle Guard (4) in place. Do not press the Trigger (3) unless the Spray Tip (5) is correctly installed in the spray position. Always lock the trigger (3) before removing, replacing or cleaning the Spray Tip (5).

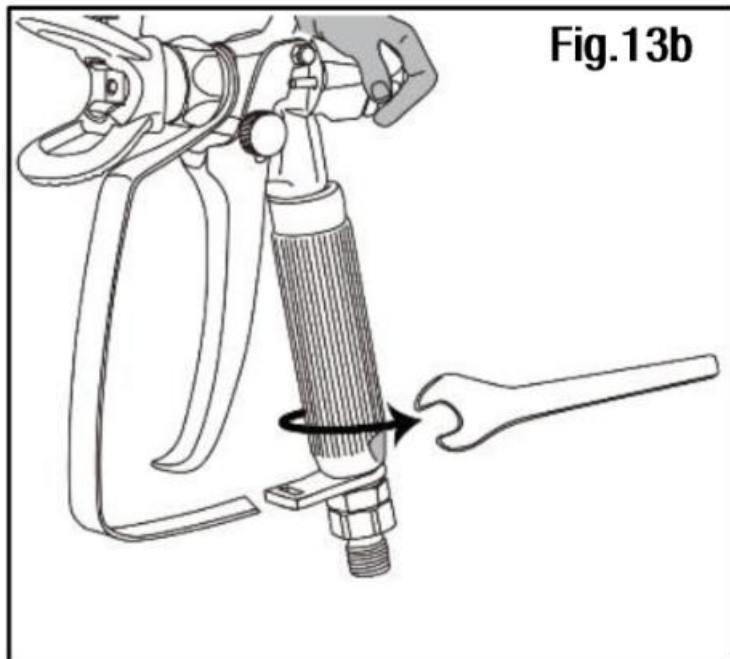
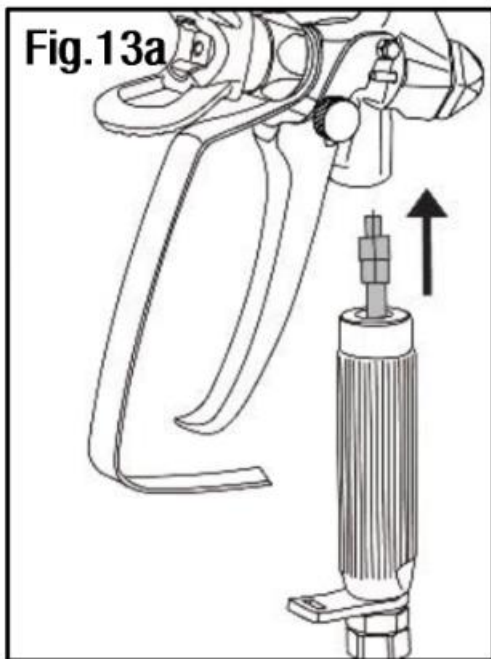

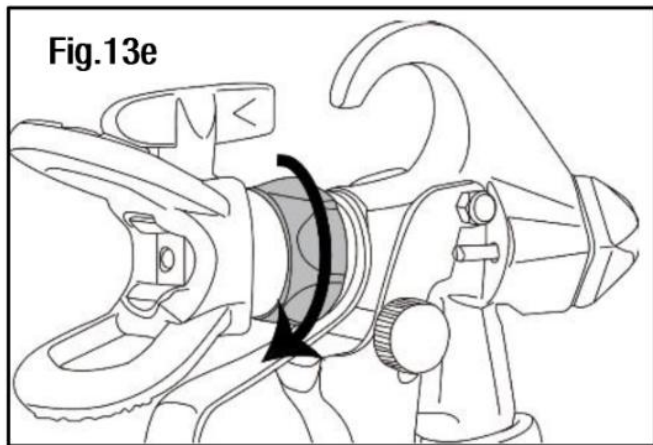
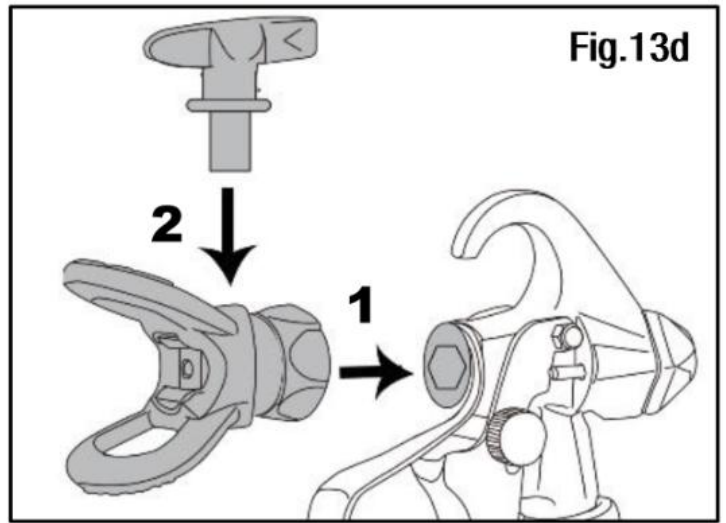
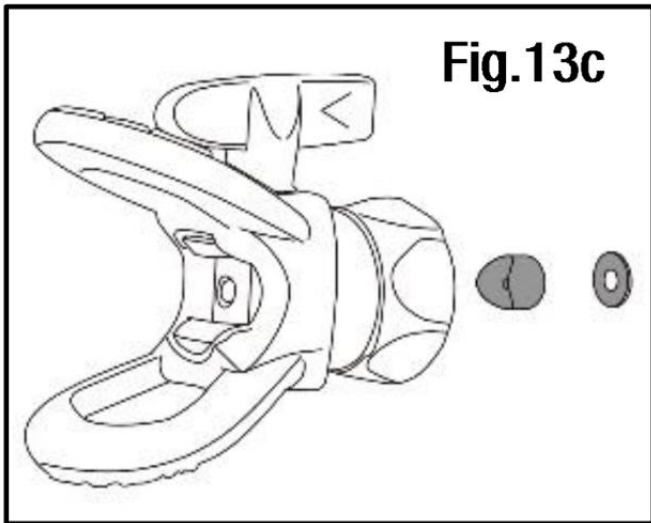

Steel ball

In the case that the paint cannot be sprayed normally, remove the suction tube and move the steel ball with a screwdriver.

1. First take out the down suction valve clamp by hand (arrow 1)
2. Take the suction tube assembly out of the down suction valve by hand (arrow 2)
3. Tilt the machine 20 degrees and use a screwdriver to move the steel ball. (Arrow 3)
4. After confirming that the steel ball is loose, reassemble all parts according to the reverse program: fully insert the suction tube (arrow 2) into the lower suction valve by hand

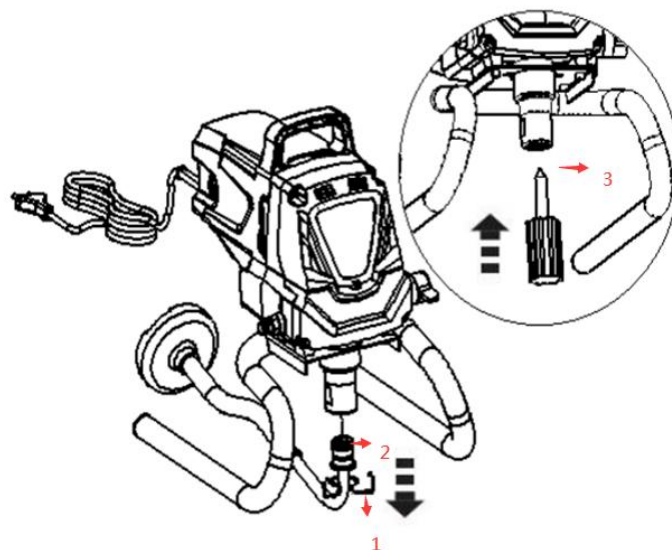

Long Term Storage

Follow all cleaning procedures after each use. Ensure the unit is thoroughly cleaned before storing to prevent build-up of dried paint which may cause blockages and stop the unit from working.

1. Perform ALL cleaning procedures
2. Remove the Spray Hose (1).
3. Remove the Suction Hose (16) from the Suction Hose Inlet Port (17) by squeezing the dogleg pin.
4. Remove the Return Hose (13) from the Return Hose Inlet Port (12) by unscrewing the nut.
5. Turn the machine upside down. Add 30mls of household oil or a pump protector oil into each inlet port.
6. Set the Prime/Spray Switch (11) to "SPRAY" position.
7. Hold a rag over the Spray Hose Outlet Port (18).
8. Switch ON the machine for 5 SECONDS by pressing the "I" on the On/Off Switch (10). Then Switch OFF the machine by pressing the "O" on the On/Off Switch (10).
9. Set the Prime/Spray Switch (11) to "PRIME" position.
10. Replace the Suction Hose (16) to the Suction Hose Inlet Port (17), and use the dogleg pin to secure the Suction Hose (16) in place.
11. Replace the Return Hose (13) to the Return Hose Inlet Port (12).
12. Wipe the sprayer housing with a clean dry cloth.
13. Store the sprayer and its accessories in a clean, dry location, out of the reach of children.

14. DISPOSAL INSTRUCTIONS



Tools that are no longer usable should not be disposed of with household waste but in an environmentally friendly way. Please recycle where facilities exist in your area. Check with your local council authority for recycling advice.

Dispose of hazardous waste, such as paint, varnishes and thinners safely. Contact your local council authority for advice on disposal and recycling services.



Recycling packaging reduces the need for landfill and raw materials. Reuse of recycled material decreases pollution in the environment. Please recycle packaging where facilities exist. Check with your local council authority for recycling advice.

15. DECLARATION OF CONFORMITY



SODILOG SAS
4 RUE CURIE, CS 91617 68016 COLMAR CEDEX FRANCE

Declare that the machine:
AIRLESS PAINT SPAYER
Model: AIRWIN1000W

S/N : 20260207261-20260208760

Is in conformity with the directive « machine » 2006/42/EC

And also with the following directive:

Directive EMC 2014/30/EU

Rohs Directive:(EU)2015/863 amending 2011/65/EU

And in conformity with the following standards:

EN 12621:2006/A1:2010

EN IEC 55014-1:2021

EN IEC 55014-2:2021

EN IEC 61000-3-2:2019/A1:2021

EN 61000-3-3:2013/A2:2021

Responsible of technical file: M. Olivier Patriarca

COLMAR CEDEX, 01/11/2025

A handwritten signature in blue ink, appearing to read 'Jacques Masson', written over a light blue rectangular background.

Jacques Masson/PDG

16. WARRANTY

The manufacturer guarantees the product against defects in material and workmanship for a period of 5 years from the date of the original purchase. It can be extended by one year if the user subscribes to website of myswap. The warranty only applies if the product is for household use. The warranty does not cover breakdowns due to normal wear and tear.

The manufacturer agrees to replace parts identified as defective by the designated distributor. The manufacturer does not accept responsibility for the replacement of the machine, in whole or in part, and/or ensuing damage.

The warranty does not cover breakdowns due to:

- insufficient maintenance.
- abnormal assembly, adjustment or operations of the product.
- parts subject to normal wear and tear.

The warranty does not extend to:

- shipping and packaging costs.
 - using the tool for a purpose other than that for which it was designed.
 - the use and maintenance of the machine done in a manner not described in the user manual.
- Due to our policy of continuous product improvement, we reserve the right to alter or change specifications without notice. Consequently, the product may be different from the information contained therein, but a modification will be undertaken without notice if it is recognized as an improvement of the preceding characteristic.

READ THE MANUAL CAREFULLY BEFORE USING THE MACHINE.

When ordering spare parts, please indicate the part number or code, you can find this in the spare parts list in this manual. Keep the purchase receipt; without it, the warranty is invalid. To help you with your product, we invite you to contact us by phone or via our website:

+33 (0)9.70.75.30.30

<https://services.swap-europe.com/contact>

You must create a "ticket" via the web platform.

- Register or create your account.
- Indicate the reference of the tool.
- Choose the subject of your request.
- Describe your problem.

Attach these files: invoice or sales receipt, photo of the identification plate (serial number), photo of the part you need (for example: pins on the transformer plug which are broken).



17. PRODUCT FAILURE

WHAT TO DO IF MY MACHINE BREAKS DOWN?

If you bought your product in a store:

- Make sure that your machine is complete with all accessories supplied, and clean! If this is not the case, the repairer will refuse the machine.
- Go to the store with the complete machine and with the receipt or invoice.

If you bought your product on a website:

- Make sure that your machine is complete with all accessories supplied, and clean! If this is not the case, the repairer will refuse the machine.
- Create a SWAP-Europe service ticket on the site: <https://services.swap-europe.com> When making the request on SWAP-Europe, you must attach the invoice and the photo of the nameplate (serial number).

Contact the repair station to make sure it is available before dropping off the machine.

Go to the repair station with the complete machine packed, accompanied by the purchase invoice and the station support sheet downloadable after the service request is completed on the SWAP-Europe site

Please keep your original packaging to allow for after-sales service returns or pack your machine with a similar cardboard box of the same dimensions.

For any question concerning our after-sales service you can make a request on our website <https://services.swap-europe.com>

Our hotline remains available at +33 (9) 70 75 30 30.



18. WARRANTY EXCLUSIONS

THE WARRANTY DOES NOT COVER:

- Start-up and setting up of the product.
- Damage resulting from normal wear and tear of the product.
- Damage resulting from improper use of the product.
- Damage resulting from assembly or start-up not in accordance with the user manual.
- Periodic and standard maintenance events.
- Actions of modification and dismantling that directly void the warranty.
- Products whose original authentication marking (brand, serial number) has been degraded, altered or withdrawn.
- Replacement of consumables.
- The use of non-original parts.
- Breakage of parts following impacts or projections.
- Accessories breakdowns.
- Defects and their consequences linked to any external cause.
- Loss of components and loss due to insufficient screwing.
- Cutting components and any damage related to the loosening of parts.
- Overload or overheating.
- Poor power supply quality: faulty voltage, voltage error, etc.
- Damages resulting from the deprivation of enjoyment of the product during the time necessary for repairs and more generally the costs related to the immobilization of the product.
- The costs of a second opinion established by a third party following an estimate by a SWAP-Europe repair station
- The use of a product which would show a defect or a breakage which was not the subject of an immediate report and/or repair with the services of SWAP-Europe.
- Deterioration linked to transport and storage*.

* In accordance with transport legislation, damage related to transport must be declared to carriers within 48 hours maximum after observation by registered letter with acknowledgement of receipt. This document is a supplement to your notice, a non-exhaustive list.

Attention: all orders must be checked in the presence of the delivery person. In case of refusal by the delivery person, it you must simply refuse the delivery and notify your refusal.

Reminder: the reserves do not exclude the notification by registered letter with acknowledgement within 72 hours.

Information:

Thermal devices must be wintered each season (service available on the SWAP-Europe site). Batteries must be charged before being stored.

FEIDER

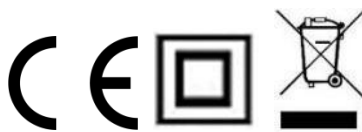

SODILOG SAS
4 RUE CURIE, CS 91617 68016 COLMAR CEDEX FRANCE
www.sodilog.com
Made in PRC